



### Accessory box

Strike plate

2 Keys

2 Keycards

CR2 battery

Long cap

2 Strike plate screws

2 Bolt plate screws

2 Security bolts

### Paddle housing



Motor  
(under housing)

### Bolt



### Key housing



### What you need:

- ✓ Phillips screwdriver
- ✓ Compatible iOS® or Android™ phone

## 01 Test your deadbolt.

Make sure your current deadbolt throws smoothly without pushing or pulling the door.

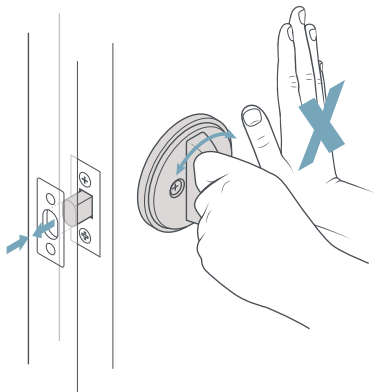

## 02 Disassemble your lock.

Unscrew your existing lock housing, deadbolt, and strike plate.

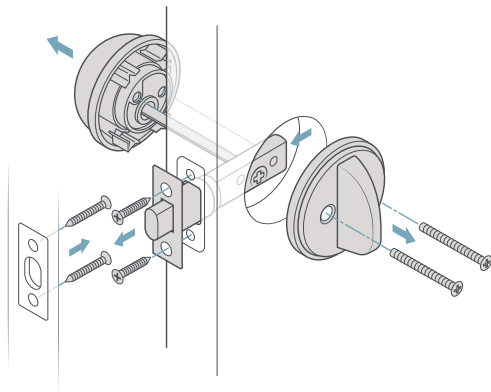

### 03 Install your Level Lock and strike plate.

A. Insert the included bolt into your door with the word TOP facing up. Look through the borehole—if you can see the end of the bolt sticking out, you're good to go to step C.

B. If you can't, simply take it out of your door and use a screwdriver to extend the bolt. Ensure the bolt snaps into place and put it back in your door, with the word TOP facing up.

C. Using a phillips screwdriver, fasten the bolt with the provided bolt plate screws.

D. Slide on the motor and make absolutely sure to **tighten the connecting screw**.

E. Fasten the strike plate to your door jamb with the provided strike plate screws.

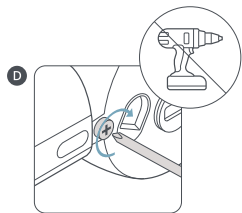
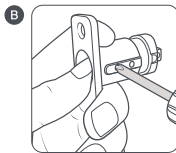
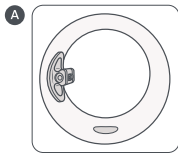
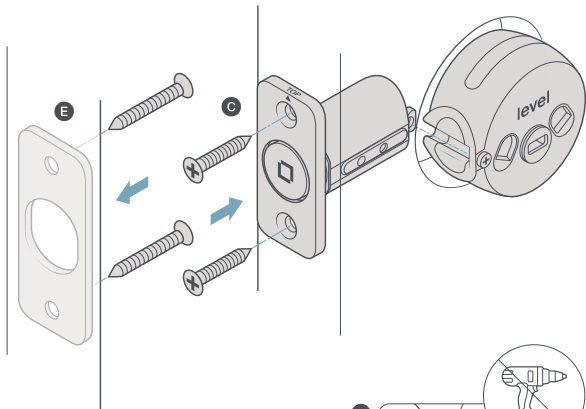

Do not use power tools.  
Power tools can easily strip screws.

## 04 Reassemble your lock using the Level Lock housing.

Make sure the bolt is retracted (unlocked).

A. Using the included housing, thread the tailpiece on the keyhole side through the center hole in the motor and screw the two sides together with the provided security bolts.

B. Snap the paddle in vertically to hide the security bolts.\*

\*To disassemble in the future, use a paperclip or pen to press the small hole on the bottom of the paddle, pulling away from the door to release it.

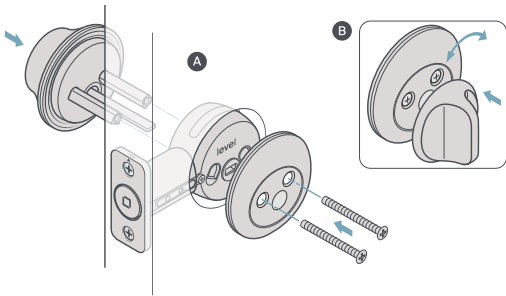

## 05 Activate your Level Lock.

Unscrew the cap on the end of the bolt and insert the battery with the flat (negative) end towards the cap. If you adjusted the bolt to the long position, use the included long cap instead of the standard cap. When you screw it back in, you'll hear a welcome chirp.

Download the Level Home app for iOS® or Android™, create an account, and connect to your Level Lock. The Level Lock works with HomeKit™, Ring and Alexa.

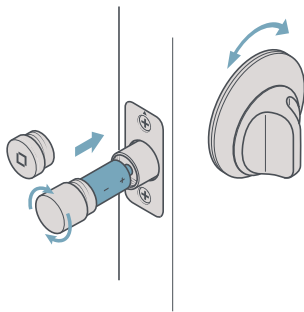

# level Lock

## Touch Edition

To enable HomeKit, scan this code during the installation steps in the Level app:



Support 7 days a week. Visit [www.level.co/support](http://www.level.co/support) for additional help.  
2-year limited warranty. Visit [www.level.co/warranty](http://www.level.co/warranty) for more information.

This device complies with part 15 of the FCC Rules. Operation is subject to the following two conditions: (1) This device may not cause harmful interference, and (2) this device must accept any interference received, including interference that may cause undesired operation. For more information on FCC compliance, please go to [www.level.co/FCC](http://www.level.co/FCC)

The Level Lock Touch Edition is BHMA Grade AAA certified. You assume all risk and responsibility in relation to the installation and performance of the lock and any third party components and services used in relation to the lock.

Please follow these suggestions and safeguards to decrease the chances of damage to your Level Lock and to lessen the risk of harm or injury:

- Use the lock for its intended purposes only.
- Keep body parts away from the lock during operation to avoid injury.
- Do not crush, perforate, drop, throw, or try to deform the lock or battery.
- Do not short external contacts or circuits, expose your lock or battery to water, liquids, or open flames or lit substances, or dispose of them in fire, solvents, or water.
- Do not use the lock or battery if they aren't working properly or have been damaged or cracked.
- Dispose of the lock and battery in accordance with local requirements.
- Do not charge CR2 lithium batteries.

Battery life varies with usage.

Caution: This product comes with small parts and parts with sharp edges that may cause injury or create a choking hazard. To avoid injury or damage, keep away from children.

Revision 1.0